

Cable Pulling Winches 20 – 100 kN

Type KW 2000 – KW 3000 – KW 4000 – KW 5000 – KW 10



The sturdy cable pulling winches of this series have proved to be highly reliable in continual service for telecommunication line and electricity supply cable laying projects.

The winches of this series are easy to operate. A single lever ensures jerk-free, infinitely variable rope speed control from 0 to 60 m/min., depending on the type of winch used. This allows the wire rope to be blown into the duct.

The winches are driven by diesel engines via infinitely variable hydrostatic transmissions. The entire pulling force is generated by a twin capstan assembly without undue stress on the wire rope.

The pulling force, together with the length of cable pulled, is recorded by an electronic printer with adjustable pull limiting switch.

The closed, soundproofed body reduces the noise level to a minimum. No troublesome preparatory work is needed, except anchoring the winch, opening the shutter over the operating panel and starting up the engine.



Specifications are subject to change without notice. Output details are depending on use conditions.

Bagela[®]

Cable Pulling Winches 20 – 100 kN

Type KW 2000 – KW 3000 – KW 4000 – KW 5000 – KW 10



Standard design:

- Chassis with overrunning and automatic reversing brake system, 12 V lighting system and TÜV-approval
- Lockable, soundproofed sheet metal hood
- Electronic diagram recorder with adjustable pull limiting switch
- Electronic meter counter
- Operating hour counter
- Diesel engine with hydrostatic gear system
- Twin capstan system with rope storage drum and 500 m rope
- Painting: traffic red RAL 3020

Extras: (on request)

- other types of engines, painting or rope lengths
- Telescopic deflection boom

Dimensions and weights may differ if extras are fitted.

Technical Data:

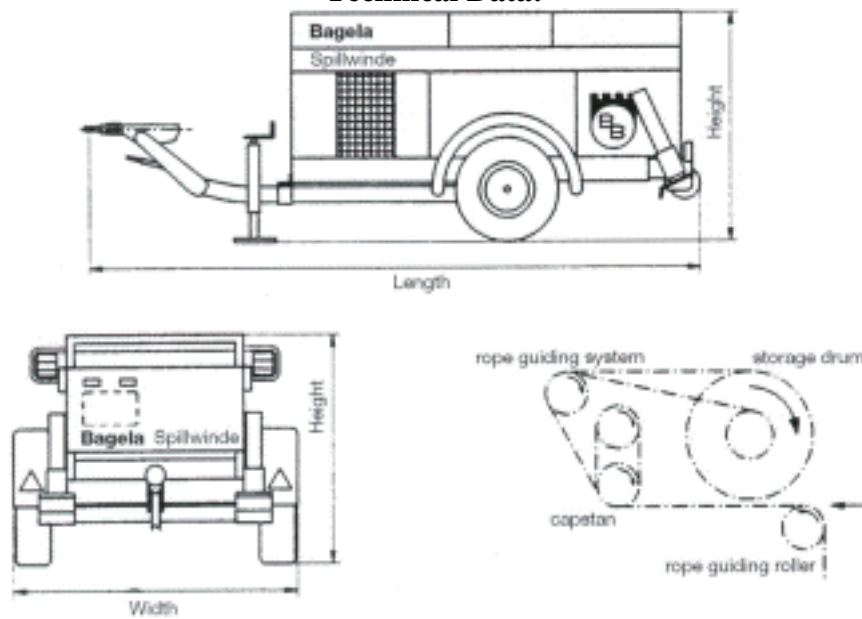

-o single-straight

-o single-height-adj.

-oo tandem-straight

-oo tandem-height-adj.

Type	Max. pulling		Drive engine			Rope		Chassis		Length	Width	Height	Weight	Order No.
	force	speed	kW	fuel	cyl.	dia.	length	type	brake					
KW 2000	20 kN	70 m/min	15	Diesel	3 W	8 mm	500 m	-o 1,6	over- running	3200 mm	1650 mm	1300 mm	1250 kg	001.712.13
KW 3000	30 kN	50 m/min	15	Diesel	3 W	10 mm	500 m	-o 1,6	over- running	3500 mm	1650 mm	1300 mm	1300 kg	001.713.06
KW 3000	30 kN	50 m/min	20	Diesel	4 W	10 mm	500 m	-o 1,75	over- running	4200 mm	1650 mm	1300 mm	1400 kg	001.713.13
KW 4000	40 kN	50 m/min	20	Diesel	4 W	11 mm	500 m	-oo 2,0	over- running	4200 mm	1600 mm	1250 mm	1500 kg	001.713.31
KW 5000	50 kN	40 m/min	20	Diesel	4 W	12 mm	500 m	-oo 2,0	over- running	4200 mm	1600 mm	1250 mm	1650 kg	001.714.02
KW 10	100 kN	30 m/min	23	Diesel	4 W	16 mm	500 m	-oo 2,5	over- running	4600 mm	1820 mm	1420 mm	2500 kg	002.003.53

Specifications are subject to change without notice. Output details are depending on use conditions.